

FS-10798 Series – Externally Adjustable for Water, Oils and Gases

Flow Rate Settings: Liquids: Infinite Adjustment between 0.5 GPM and 20.0 GPM
Air/Gases: See Gas Flow Adjustment Ranges below

Port Size: 1/2-14 NPT

Primary Construction Material: Brass or Stainless Steel

Setting Type: Adjustable

These externally adjustable switches are ideal for protecting machine tools from coolant flow failure, for protecting bearings from loss of lubricant or to assure proper air flow. They offer an infinite number of flow settings at pressures up to 1000 PSIG, with low pressure drop and precise repeatability.

The adjusting vane is easily field adjustable using an ordinary flat-bladed screwdriver. The adjustment is set-screw-locked for tamper-free operation after field calibration.

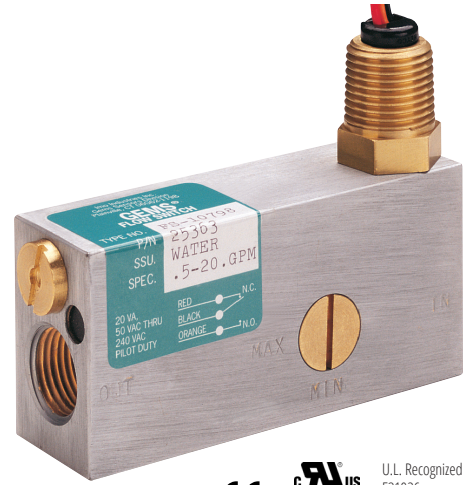

Shown with optional 1/2" conduit connector.



U.L. Recognized — File No. E31926



Specifications

Wetted Materials	
Housing	Brass or 316 Stainless Steel
Piston	
In Brass Housing	Polysulfone for water; Brass for oil or air
In Stainless Steel Housing	316 Stainless Steel Only
Spring	316 Stainless Steel
O-Ring	Viton®
Other Wetted Parts	Epoxy
Pressure Rating	
Operating	1000 PSIG (69 bar)
Proof	2500 PSIG (172 bar)
Burst	5000 PSIG (345 bar)
Operating Temperature	
With Brass or S.S. Piston	-20°F to +300°F (-29°C to +148.9°C)
With Polysulfone Piston	-20°F to +225°F (-29°C to +107.2°C)
Repeatability	1% Maximum Deviation
Set Point Accuracy	±10% Maximum
Set Point Differential	15% Maximum
Switch*	SPDT, 20 VA
Inlet/Outlet Ports	1/2-14 NPT
Electrical Termination	No. 18 AWG, 24" L., Polymeric Lead Wires

*See "Electrical Data" on Page X-5 for more information.

Air/Gas Flow Adjustment Ranges

Water or oil flow units should not be utilized for air/gas applications. The FS-10798 Gas Flow configuration utilizes a special dash-pot piston for reliability. The flow adjustment ranges are typical for air service. For other gases, the flow range will vary with the density of the gas. Please consult factory for more information.

For 5 PSIG Line*	1 to 75 SCFM Approx.
For 100 PSIG Line	3 to 160 SCFM Approx.

* Minimum 5 PSI line pressure required.

Dimensions

With Wire Leads and Strain Relief

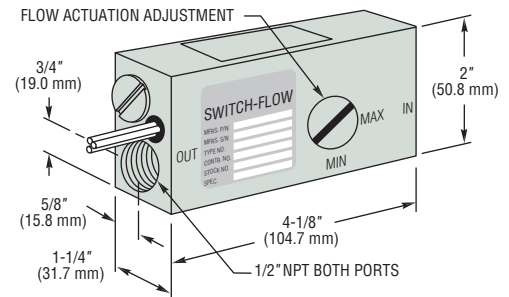

With 1/2-14 NPT Conduit Connector

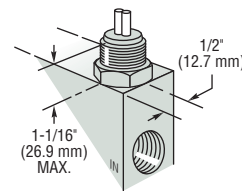

How It Works

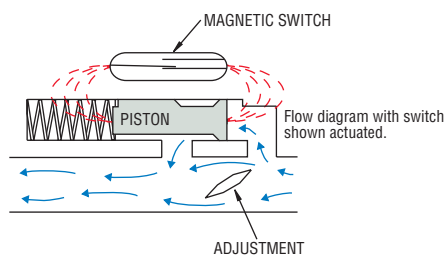
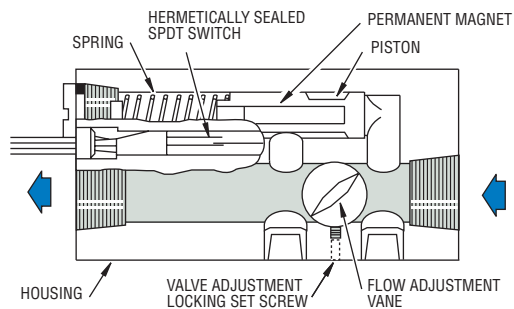

An externally rotatable vane is positioned in the main flow path within the unit. The magnet carrier piston is located in a bypass flow chamber. Pressure differential, caused by flow around the adjusting vane, displaces the spring-biased piston which actuates a hermetically sealed SPDT reed switch within the unit.

How To Order – Standard Models

Specify Part Number based on desired media, piston material and electrical termination.

Media	Materials		Part Numbers	
	Housing	Piston	With Lead Wires	With 1/2" Conduit Connector
Liquids	Brass	Brass (for Oils)	61205	49073 ⚡
		Polysulfone (for Water)	25357 ⚡	25363 ⚡
		316 Stainless Steel	25358	25364 ⚡
Gases		Brass	25359 ⚡	25365 ⚡
		316 Stainless Steel	25360	25366

- Notes:
- Temperature changes will slightly affect the standard water or gas flow settings listed. Oil flow settings will vary with temperature and viscosity.
 - Use of 50 micron filtration is recommended.

⚡ – Stock Items.

Pressure Drop - Typical

0.5 GPM

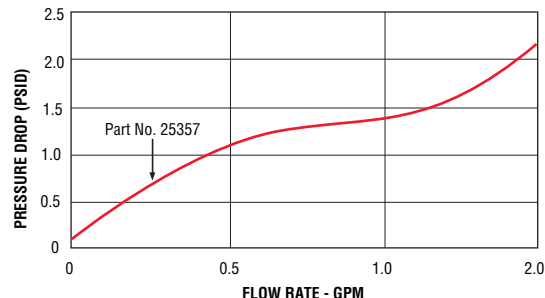

10 GPM and 20 GPM

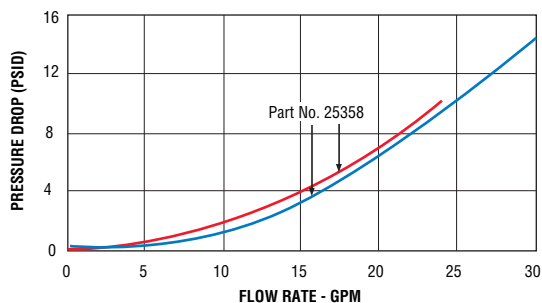

Tests conducted with units in horizontal position with water at +70°F (21°C). Data will vary slightly for vertically mounted units.

FS-10798 switches are U.L. Approved for Class I, Division 2, Groups A, B, C, D hazardous locations. U.L. Approved — File No. E183854

Standard Wiring Color Code

Wire Color	Terminal
Orange	N.O.
Black	Common
Red	N.C.